

VOLVO PENTA GENSET ENGINE

TAD1032GE

1500 rpm, 292 kW (397 hp)

1800 rpm, 287 kW (390 hp)

Reliable & powerful

The TAD1032GE is a powerful, reliable and economical Generating Set diesel built on the dependable in-line six design.

Durability & low noise

Designed for easiest, fastest and most economical installation. Well-balanced to produce smooth and vibration-free operation with low noise level.

To maintain a controlled working temperature in cylinders and combustion chambers, the engine is equipped with piston cooling. The engine is also fitted with replaceable cylinder liners and valve seats/guides to ensure maximum durability and service life of the engine.

Low exhaust emission

The state of the art, high-tech injection and charging system with low internal losses contributes to excellent combustion and low fuel consumption.

The TAD1032GE complies with EPA/CARB Tier 1 and TA-Luft exhaust emission regulations.

Easy service & maintenance

Easily accessible service and maintenance points contribute to the ease of service of the engine.

Technical description:

Engine and block

- Optimized cast iron cylinder block with optimum distribution of forces without the block being unnecessarily heavy.
- Wet, replaceable cylinder liners with flame barrier that protects the cylinder head gaskets against high temperatures.
- Piston cooling for low piston temperature and reduced ring temperature
- Tapered connecting rods to reduce risk of piston cracking
- Nitrocarburized crankshaft with seven bearings for moderate load on main bearings
- Nitrocarburized transmission gears for heavy duty operation
- Keystone top compression rings for long service life
- Viscous type crankshaft vibration dampers to withstand single bearing alternator torsional vibrations
- Replaceable valve guides and valve seats

Lubrication system

- Full flow oil cooler
- Full flow disposable spin-on oil filter, for extra high filtration
- The lubricating oil level can be measured during operation
- Gear type lubricating oil pump, gear driven by the transmission

Fuel system

- Bosch fuel injection system including accurate electronic governor.
- Non-return fuel valve
- Twin fuel filters of disposable type.
- Gear type lubricating oil pump, gear driven by the transmission.
- Fine fuel filter with manual feed pump and fuel pressure switch

Turbo charger

- Efficient and reliable turbo charger

Cooling system

- Air to air intercooler
- Gear driven, maintenance-free coolant pump with high degree of efficiency
- Efficient cooling with accurate coolant control through a water distribution duct in the cylinder block. Reliable sleeve thermostat with minimum pressure drop
- Automatic fan drive belt tensioner.

Electrical system

- Electronic speed governor system controls the engine speed in droop or isochronous mode. The system includes a control unit, speed sender and electro-magnetic actuator (ACB275)

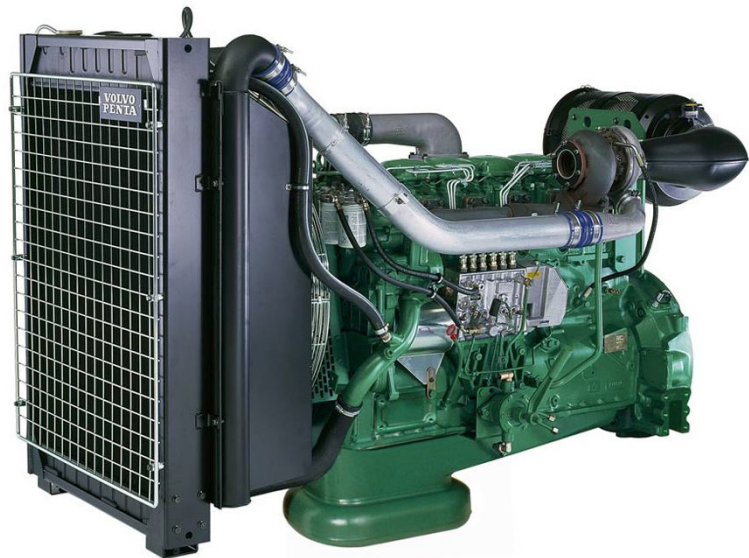

Features

- Maintained performance, air temp 40°C, altitude 1000 m
- Tropical cooling system (55°C)
- Guaranteed power output 0 to +2%
- El. Governing (GAC-ACB275)
- Low exhaust emissions
- Low noise levels
- Gen Pac configuration

**VOLVO
PENTA**

TAD1032GE

Technical Data

General

Engine designation	TAD1032GE	
No. of cylinders and configuration	in-line 6	
Method of operation	4-stroke	
Bore, mm (in.)	120 (4.75)	
Stroke, mm (in.)	140 (5.51)	
Displacement, l (in ³)	9.6 (585.8)	
Compression ratio	17.0:1	
Dry weight, kg (lb)	1107 (2439)	
With Gen Pac, kg (lb)	1254 (2765)	
Wet weight, kg (lb)	1163 (2564)	
With Gen Pac, kg (lb)	1325 (2919)	

Performance

	1500rpm	1800 rpm
with fan, kW (hp)	266 (362)	262 (356)
Prime Power	292 (397)	287 (390)
Maximum Standby Power		

Lubrication system

	1500rpm	1800 rpm
Oil consumption at liter/h (US gal/h)	0.05 (0.011)	0.05 (0.011)
Prime Power	0.06 (0.013)	0.06 (0.013)
Maximum Standby Power		
Oil system capacity incl filters, liter (US gal)	36 (9.5)	
Oil change intervals at specification		
VDS-2, h	600	
VDS, ACEA E3, h	400	
ACEA E1, E2, API CD, CF, CF-4, CG-4, h	200	

Fuel system

	1500rpm	1800 rpm
Specific fuel consumption at Prime Power, g/kWh (lb/hph)	223 (0.361)	250 (0.405)
25 %	205 (0.332)	205 (0.332)
50 %	201 (0.326)	200 (0.324)
75 %	207 (0.336)	208 (0.337)
100 %		
Max Standby Power, g/kWh (lb/hph)	223 (0.361)	225 (0.365)
25 %	204 (0.331)	203 (0.329)
50 %	204 (0.331)	199 (0.323)
75 %	211 (0.342)	210 (0.340)
100 %		

Intake and exhaust system

	1500rpm	1800 rpm
Air consumption at 25°C, m ³ /min (cfm)	17.9 (632)	21.6 (763)
Prime Power	20.1 (710)	23.3 (823)
Standby Power		
Max allowable air intake restriction, kPa (In wc)	5 (20.1)	
Heat rejection to exhaust, kW (BTU/min)	208 (11829)	224 (12739)
Prime Power	238 (13535)	250 (14217)
Max Standby power		
Exhaust gas temperature after turbine, °C (°F)	510 (950)	480 (896)
Prime Power	520 (968)	490 (914)
Max Standby Power		
Max allowable back-pressure in exhaust line, kPa (In wc)	5 (20.1)	
Exhaust gas flow, m ³ /min (cfm)	46.0 (1624)	52.0 (1836)
Prime power	52.0 (1836)	57.3 (2024)
Max Standby Power		

Cooling system

	1500rpm	1800 rpm
Heat rejection radiation from engine, kW (BTU/min)	14 (796)	15 (853)
Prime Power	16 (910)	17 (967)
Max Standby Power		
Heat rejection to coolant kW (BTU/min)	105 (5971)	107 (6085)
Prime Power	112 (6369)	115 (6540)
Max Standby Power		
Fan power consumption kW (hp)	4 (5)	7 (10)

Standard equipment

	Engine	Gen Pac
Engine		
Automatic belt tensioner	•	•
Lift eyelets	•	•
Flywheel		
Flywheel housing with conn. acc. to SAE 1	•	•
Flywheel for 14" flex. plate and flexible coupling	•	•
Vibration damper	•	•
Engine suspension		
Fixed front suspension	—	•
Lubrication system		
Oil dipstick	•	•
Full-flow oil filter of spin-on type	•	•
Fuel system		
Twin fuel filters of disposable type	•	•
Flexible fuel lines	—	•
Fuel injection pump, Bosch, with GAC electrical governor	•	•
Pump and coupling guard	•	•
Intake and exhaust system		
Air filter of disposable type	•	•
Air restriction indicator	•	•
Air cooled exhaust manifold	•	•
Connecting flange for exhaust line	•	•
Turbo charger	•	•
Heat guard for exhaust pipe and turbo	•	•
Crankcase ventilation	•	•
Cooling system		
Tropical radiator and intercooler	• ¹⁾	•
Radiator guard	—	•
Gear driven coolant pump	•	•
Fan hub	•	•
Thrust fan	—	•
Fan guard	—	•
Belt guard	—	•
Alternator		
Alternator 60A / 24V low, right side	•	•
Starting system		
Starter motor,	•	•
Electrical wiring		
Cable iron	•	•
Instruments and senders		
Temp.- and oil pressure for automatic stop/alarm 103°C	—	•
Other equipment		
Expandable base frame	—	•
Engine Packing		
Plastic wrapping	•	•

1) must be ordered, see order specification - optional equipment
 — optional equipment or not applicable
 • included in standard specification

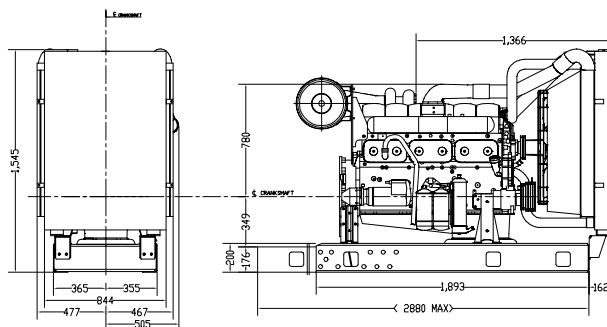

Note! The engine illustrated may not be entirely identical to production standard engines.

Power Standards

The engine performance corresponds to ISO 3046, BS 5514 and DIN 6271. The technical data applies to an engine without cooling fan and operating on a fuel with calorific value of 42.7 MJ/kg (18360 BTU/lb) and a density of 0.84 kg/liter (7.01 lb/US gal), also where this involves a deviation from the standards. Power output guaranteed within 0 to +2% att rated ambient conditions at delivery. Ratings are based on ISO 8528. Engine speed governing in accordance with ISO 3046/IV, class A1 and ISO 8528-5 class G3

Exhaust emissions

The engine complies with EPA / CARB - Tier 1 and TA-luft exhaust emission regulations.

Rating Guidelines

PRIME POWER rating corresponds to ISO Standard Power for continuous operation. It is applicable for supplying electrical power at variable load for an unlimited number of hours instead of commercially purchased power. A10 % overload capability for governing purpose is available for this rating. MAXIMUM STANDBY POWER rating corresponds to ISO Standard Fuel Stop Power. It is applicable for supplying standby electrical power at variable load in areas with well established electrical networks in the event of normal utility power failure. No overload capability is available for this rating.
 1 hp = 1 kW x 1.36

Information

For more technical data and information, please look in the Generating Set Engines Sales Guide.

VOLVO PENTA

AB Volvo Penta

SE-405 08 Göteborg, Sweden
 www.volvopenta.com