

GV222TI GEN-PACK

◎ POWER RATING

Engine Speed rev/min	Type of Operation	Engine Power	
		kWm	PS
1800	Prime Power	410	557
	Standby Power	451	613
1500	Prime Power	350	476
	Standby Power	385	523



Note : -. The engine performance corresponds to ISO 3046, BS 5514 and DIN 6271.

* Without cooling fan, inter cooler inlet water temperature 32 °C

- Ratings are based on ISO 8528.

→ **Prime power** available at variable load. The permissible average power out put (during 24h period) shall not exceed 70% of the prime power rating. No overload is permitted.

→ **Standby power** available in the event of a main power network failure. No overload is permitted.

◎ MECHANICAL SYSTEM

- Engine Type V-type 4 cycle, water cooled
Turbo charged & intercooled (water to air)
- Combustion type Stoichiometric, Premixed and spark ignited
- Cylinder Type Replaceable wet liner
- Number of cylinders 12
- Bore x stroke 128(5.04) x 142(5.59) mm(in.)
- Displacement 21.927 (1,338.0) lit.(in³)
- Compression ratio 10.5 : 1
- Firing order 1-12-5-8-3-10-6-7-2-11-4-9
- Ignition timing 12° BTDC
- Compression pressure Above 28 kg/cm2(398 psi) at 200rpm
- Dry weight (Engine) Approx. 1,620 kg (3,572 lb)
- Dimension (Engine) 1,924 x 1,243 x 1,626 mm
(LxWxH) (75.7 x 48.9 x 64 in.)
- Rotation Counter clockwise viewed from Flywheel
- Fly wheel housing SAE NO.1
- Fly wheel Clutch NO.14

◎ MECHANISM

- Type Over head valve
- Number of valve Intake 1, exhaust 1 per cylinder
- Valve lashes at cold Intake 0.3mm (0.0118 in.)
Exhaust 0.4mm (0.0157 in.)

◎ VALVE TIMING

- | | Opening | Close |
|-----------------|--------------|--------------|
| ○ Intake valve | 24 deg. BTDC | 36 deg. ABDC |
| ○ Exhaust valve | 63 deg. BBDC | 27 deg. ATDC |

◎ FUEL CONSUMPTION

- | ○ Prime (Nm ³ /hr) | 1,500 rpm | 1,800 rpm |
|-------------------------------|-----------|-----------|
| 25% | 25.6 | 37.5 |
| 50% | 49.2 | 62.0 |
| 75% | 73.4 | 89.4 |
| 90% | 88.2 | 103.3 |
| 100% | 95.2 | 107.2 |
-
- | ○ Standby (Nm ³ /hr) | 1,500 rpm | 1,800 rpm |
|---------------------------------|-----------|-----------|
| 100% | 105.6 | 112.2 |

◎ FUEL SYSTEM

- Carburetor Impco 200M Varifuel carburetor (2EA)
- Gas regulator Maxitrol RV61 (2EA)
- Max. inlet pressure 1.0 psi at the engine inlet

◎ LUBRICATION SYSTEM

- Lub. Method Fully forced pressure feed type
- Oil pump Gear type driven by crankshaft
- Oil filter Full flow, cartridge type
- Oil pan capacity High level 40 liters (10.6 gal.)
Low level 33 liters (8.7 gal.)
- Lub. Oil Refer to Operation Manual
Low ash type(0.5wt%) natural gas engine oil
API service grade CD or higher
SAE 15W-40

◎ COOLING SYSTEM

- Cooling method Fresh water forced circulation
- Water capacity 44 liters (11.62 gal.) (Engine only)
- Pressure system Max. 0.5 kg/cm² (7.1 psi)
- Water pump Centrifugal type driven by belt
- Cooling fan Blower, 1070mm diameter, 12 blades
Plastic
- Loss power of fan 43PS (32kW) @ Eng. Speed 1,500 rpm
65PS (48kW) @ Eng. Speed 1,800 rpm
- Thermostat Wax – pellet type
Opening temp. 71°C
Full open temp. 85°C

◎ ELECTRICAL SYSTEM

- Charging generator 28.5V x 45A alternator
- Voltage regulator Built-in type IC regulator
- Starting motor 24V x 7.0kW
- Battery Voltage 24V
- Battery Capacity 200 AH (recommended)
- Ignition controller 12 or 24V DC
(min 8V DC at start, 32V DC max)

◎ IGNITION SYSTEM

- Spark plug NGK IFR7B-D, 0.4mm air gap
Champion RC78PYP, 0.38mm air gap
- Ignition controller Altronic CPU-95 unit (24V DC)
- Ignition coil Altronic 501 061 blue epoxy individual coil
- Trigger system Magnetic pick-up sensor and trigger wheel and Hall-effect
(0.5/ 0.5/ 1.0mm air gap)

◎ ENGINEERING DATA

- Water flow 550 liters/min @1,500 rpm
640 liters/min @1,800 rpm
- Heat rejection to coolant 90.1 kcal/sec @1,500 rpm
108.2 kcal/sec @1,800 rpm
- Heat rejection to CAC 6.1 kcal/sec @1,500 rpm
9.1 kcal/sec @1,800 rpm
- Inter cooler water flow 290 liters/min @1,500 rpm
340 liters/min @1,800 rpm
- Air flow 29.6 m³/min @1,500 rpm
35.5 m³/min @1,800 rpm
- Exhaust gas flow 47.8 m³/min @1,500 rpm
57.4 m³/min @1,800 rpm
- Exhaust gas temp. 490 °C @1,500 rpm
515 °C @1,800 rpm
- Radiator air flow 670 m³/min @1,500 rpm, 0.7kPa
720 m³/min @1,800 rpm, 1kPa
- Max. permissible restrictions
 - Intake system 220 mmH₂O initial
635 mmH₂O final
 - Exhaust system 600 mmH₂O max.
- Altitude Capability 1,500 m

◆ CONVERSION TABLE

- in. = mm x 0.0394 lb/ft = N.m x 0.737
- PS = kW x 1.3596 U.S. gal = lit. x 0.264
- psi = kg/cm² x 14.2233 kW = 0.2388 kcal/s
- in³ = lit. x 61.02 lb/PS.h = g/kW.h x 0.00162
- hp = PS x 0.98635 cfm = m³/min x 35.336
- lb = kg x 2.20462 Nm³ = SCF × 0.0283
- Kg/hr = Nm³/hr × 0.732 (natural gas)
- Btu/ft³ = MJ/m³ × 26.8392 (natural gas)
- kPa = 101.97 mmH₂O = 0.01 bar

GV222TI GEN-PACK

© Dimensions : Engine

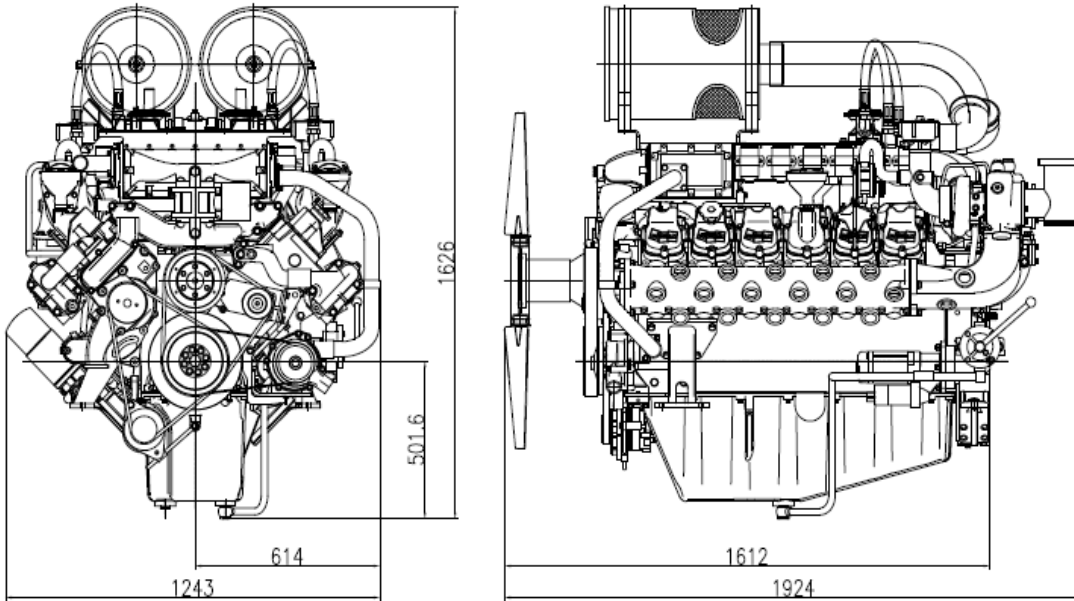

© Dimensions : Gen-pack

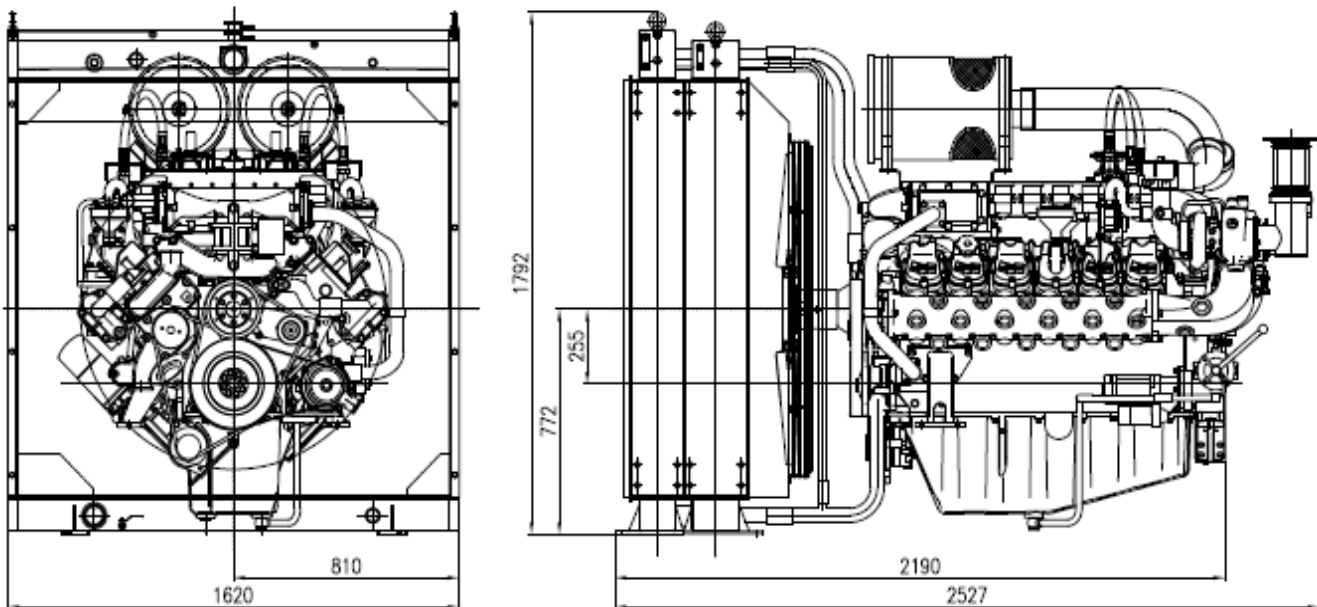

Doosan Infracore Co., Ltd.
 21st Floor, Doosan Tower, 18-12, Euljiro 6-ga,
 Jung-gu, Seoul, Korea

TEL : +82-2-3398-8400 / Fax : +82-2-3398-8509
E-mail : enginesales@doosan.com
Web site : www.doosaninfracore.com

* Specifications are subject to change without prior notice

